

# Secofoam

constructive solutions

## Multi purpose expanding polyurethane foam gap filler

One-part foam gap filler, insulant and fixative, supplied in a disposable aerosol canister for easy application.

### Uses

Secofoam is used for fixing and filling gaps around the following:

- New and replacement windows and door frames
- Pipe and duct work entries
- Thresholds and sills
- Wall chases
- Roof eaves and ridges
- Foam insulation slabs

### Advantages

- Highly flowable — fills irregular gaps
- Provides a barrier to draughts and water penetration
- High thermal insulation properties prevents heat loss through gaps
- Easy and quick to apply
- Fast curing
- Good adhesion
- Ozone friendly — contains no CFC's
- Non shrinking

### Description

Secofoam is a one component moisture cured rigid polyurethane foam which are available in pressurised disposable aerosol canisters.

The major use of Secofoam is in the installation of new and replacement window and door frames as an easy and quick method of filling gaps and clearances between the surrounding structures. The strong bond obtained and the high density cellular structure of Secofoam assists in the strength of the frame fixing and reduces the number of mechanical fixing points required. Door frames can be fixed by Secofoam alone without the need for mechanical fixings.

## Properties

<b>Form:</b>	P.U. foam
<b>Storage:</b>	Cool place out of sunlight
<b>Shelf life:</b>	9 months
<b>Density:</b>	20 to 25 kg/m <sup>3</sup>
<b>Tensile strength:</b> (BS 5241)	9 N/cm <sup>2</sup>
<b>Compressive strength at 10% compression:</b> (BS 4370)	3 N/cm <sup>2</sup>
<b>Water absorption by volume:</b>	0.3% on cured foam
<b>Foam structure:</b>	Fine homogeneous cells
<b>Colour:</b>	Pale green
<b>Physical or chemical change:</b>	Chemical cure by reaction with moisture
<b>Thermal conductivity:</b> (ASTM C518.76)	0.023 W/m/°K
<b>Application temperature:</b>	+5°C to +35°C
<b>Service temperature:</b>	-40°C to +90°C
<b>Tack free time:</b>	6 to 10 minutes at 20°C
<b>Flammability:</b>	Class B3 DIN 4102
<b>Toxicity:</b>	Toxic when wet, non toxic cured

## Application instructions

### Window frame installation (replacement windows or re-sealing)

Secofoam is suitable for use with most types of window or sub frames. Ensure the opening is free from dust and loose material before installing the frame. Secofoam reacts with moisture and it is advisable to lightly spray the surface to be foamed prior to commencement. This is especially important during warm/hot weather. Secofoam will adhere to the damp surface.

Position the frame and make the specified number of mechanical fixings. Because of the strength and adhesive qualities of Secofoam, fewer fixings are required.

The foam is injected into the gap remaining around the frame to fill slightly less than half the gap. The foam will then expand to fill the remaining depth.

Secofoam is tack free within 10 to 30 minutes and excess can normally be cut off after 2 hours. The rate of cure is dependent upon prevailing temperature and humidity conditions. Full cure normally takes place within 12 to 24 hours.

# Secofoam

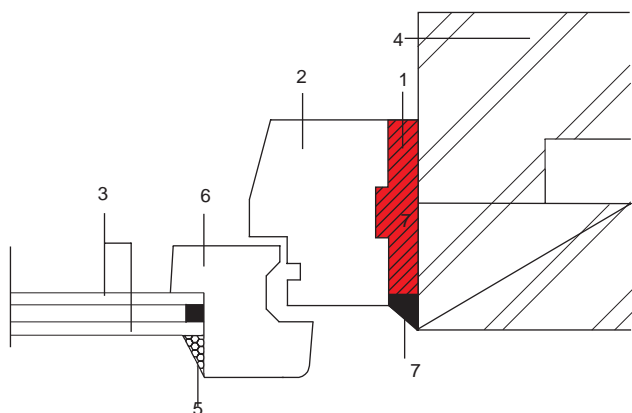

- 1 Secofoam
- 2 Frame
- 3 Glass
- 4 Brick
- 5 Putty
- 6 Window
- 7 Sealant

## Door frame installation

Brace or wedge the frame into position as required. Seal and fix by filling the gap between the frame and the surrounding structure with Secofoam. By tightly covering the frame gap opening internally with polythene, it is possible to direct Secofoam expansion outwards. Fill gap to slightly less than half the known depth and finish off as previously described under 'Window frame installation'.

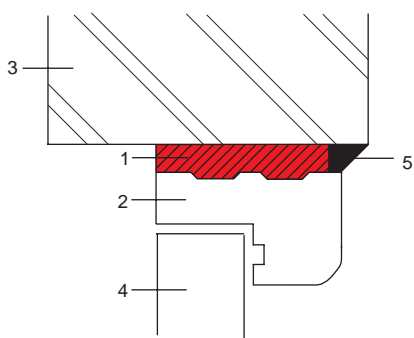

- 1 Secofoam
- 2 Frame
- 3 Brick
- 4 Door
- 5 Sealant

## Pipe and duct entries

Secofoam does not shrink and is suitable for sealing around pipes and ductwork where they pass through walls. Minor vibrations will not affect the bond. Secofoam will dampen noise transmission and will prevent the ingress of insects. When cured Secofoam may be cut or sanded and then plastered, rendered or finished with emulsion paint.

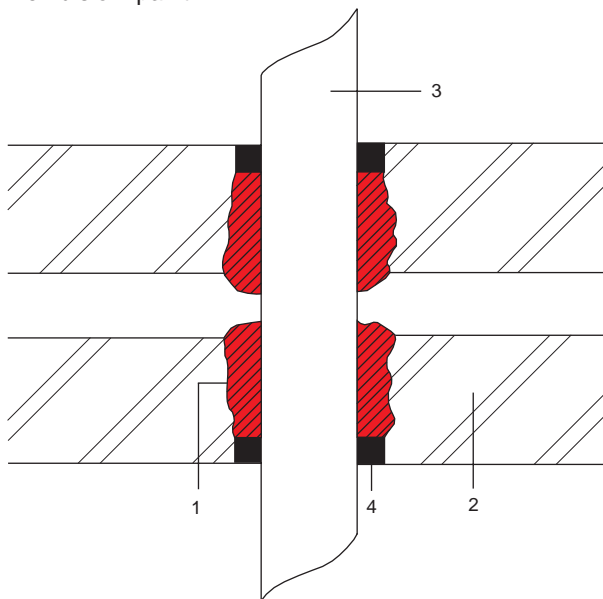

- 1 Secofoam
- 2 Brick
- 3 Pipe
- 4 Nitoseal MS50

## Insulation

Because of its acoustic and thermal insulation properties, Secofoam is recommended for filling irregular voids and gaps between insulation and cellular slabstock in caravans and refrigerated container construction, etc.

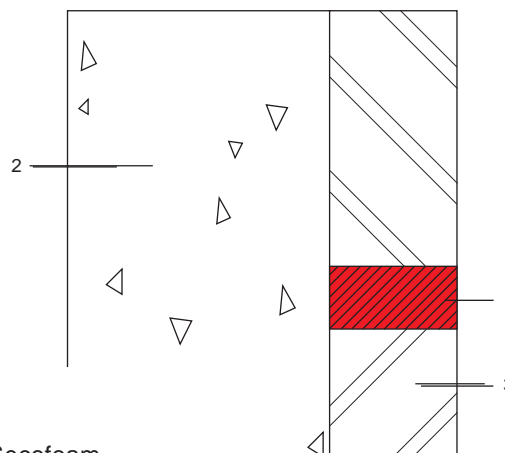

- 1 Secofoam
- 2 Concrete
- 3 Insulation board

# Secofoam

It is recommended that, for any large areas, Secofoam should be in layers of approximately 25 mm, allowing an initial cure to take place before the next application, otherwise sufficient pressure may be generated during expansion of the foam to cause deformation or damage the structure insulated.

## Others

Secofoam may be used to fill wall chases over pipes and electrical conduit and should be finished as previously described. It may also be used as an eaves or ridge filler on industrial roof details providing it is top sealed to prevent UV degradation of the foam.

## Operating instructions

1. Shake aerosol canister vigorously. Check that the contents of the canister are fluid enough to shake, if not stand in warm water for a few minutes prior to use.
2. Fix applicator mechanism to canister.
3. When required, insert canister, insert flexible tube and press applicator sideways allowing the foam to exude as required.
4. Control of the rate of application may require some initial practice. It is recommended that trials are carried out excluding beads onto waste paper or similar until a degree of competence is attained. Always press adaptor trigger slowly first. All trial material must be disposed of carefully. Any overhead work should be done first as the propellant is more powerful when canister is full.
5. When work is completed, stand canister upright for 5 minutes slowly release a small quantity of propellant to blow excess foam out of the tube and valve. Unscrew applicator and replace dust cap.

## Application guide

1. Ensure the gap is free from all loose material and lightly dampen or spray with clean water.
2. Inject the foam to fill half the gap depth and allow to rise. After each section is injected re-shake the canister and wipe nozzle regularly. Do not overfill since the foam expands many times its original volume and will continue to expand, whilst curing.

3. When the foam has hardened trim off excess with a sharp knife and protect any exposed edges from UV attack by application of suitable Fosroc sealant, plaster or paint.
4. Contents should always be fluid enough to shake, if not stand in warm water for a few minutes prior to use.

## Cleaning

Once cured Secofoam can only be removed mechanically.

## Estimating

<b>Pack size:</b>	750 ml x 12
<b>Foam, free expansion:</b>	45 times initial volume

## Limitations

Secofoam is subject to discoloration and deterioration by UV light. The foam must be cut back and protected by pointing with a suitable sealant, plaster or paint. A range of appropriate sealants are available from Fosroc.

## Precautions

### Health and safety

Secofoam contains isocyanates.

For further information please consult product Safety Data Sheet.

Secofoam is a trade mark of Fosroc International Limited



## Fosroc Limited

Drayton Manor Business Park  
Coleshill Road, Tamworth,  
Staffordshire B78 3TL. UK

[www.fosroc.com](http://www.fosroc.com)

### Important note

Fosroc products are guaranteed against defective materials and manufacture and are sold subject to its standard Conditions for the Supply of Goods and Services, copies of which may be obtained on request. Whilst Fosroc endeavours to ensure that any advice, recommendation, specification of information it may give is accurate and correct, it cannot, because it has no direct or continuous control over where or how its products are applied, accept any liability either directly or indirectly arising from the use of its products, whether or not in accordance with any advice, specification, recommendation of information given by it.

**telephone:**  
+44 (0) 1827 262222

**fax:**  
+44 (0) 1827 262444

**email:**  
uk@fosroc.com



Certificate number FM 610