

MASTERFLOW[®] 928

Ready-To Use, Non-Shrink, High Strength Grout

Description of Product

MASTERFLOW[®] 928 is a specially prepared, ready-to-use, non-shrink, high-strength grout. It is formulated for use at any consistency from fluid to damp pack for precision grouting of equipment, concrete systems, structural building members, curtain walls, precast wall panels, beams and columns. It contains natural aggregates and provides a grout that is similar in appearance to concrete and mortar. MASTERFLOW[®] 928 is the ideal product to use for a natural coloured grout.

Fields of Application

MASTERFLOW[®] 928 is recommended for:

- Grouting and precision equipment, baseplates, soleplates and columns.
- Grouting applications where shrinkage must be eliminated and where high-strength grout similar in appearance to concrete and mortar is required or desired.
- Non-shrink grouting of precast wall panels, beams and columns.
- Anchoring bolts, reinforcing bars and rods.

Features and Benefits

- A ready-to-use grout that hardens free of bleeding, settlement or drying shrinkage when mixed and placed at any consistency-fluid, flowable, plastic or damp pack.
- A grout that retains good workability upto 1 hour at 20°C.
- A non-shrink grout that can be pumped into intricate areas or areas inaccessible to conventional grouting methods.
- A non-shrink grout for use where a grout similar in appearance to concrete and mortar is required and desired.
- A grout that develops high strengths at flowable consistency without vertical confinement.

Technical Data/Typical Properties

Plastic density	2160 Kg ^m ⁻³	
Plastic expansion (ASTM C827)	+0.2%	
Hardened expansion(CRD621)	+0.2%	
Bleed	Nil	
Air content	3.5%	
Flexural Strength (BS 6319:Pt7)	7 days 7.5 NMM ⁻²	
	28 days 8.5 NMM ⁻²	
Compressive strengths of MASTERFLOW [®] 928 (at 20%)		
Consistency		
	Plastic (1) MPa (N/mm ²)	Fluid (2) MPa (N/mm ²)
1 day	40	29
3 days	58	35
7 days	68	46
28 days	80	60
Average air contents:	4.2%	
(1) 95% flow on flow table , ASTM C230, 5 drops in 3 seconds Plastic consistency of 3 L water per 25 kg bag MASTERFLOW [®] 928		
(2) 25 -30 seconds flow, by Corps of Engineers Flow Cone Method CRD-C 611 or Cerilh Cone Method Fluid consistency at 4.6 L water per 25 kg bag MASTERFLOW [®] 928		

Note

The data shown is based on controlled laboratory tests. Reasonable variations from the results shown can be expected. Field and laboratory tests should be controlled on the basis of the desired placing consistency rather than strictly on the water content.

If the work requires that strength tests be made at the jobsite or in the laboratory, do not use cylinder moulds. Consult your BASF Construction Chemicals (UK) Ltd Representative or Technical Services Department for special procedures required when mixing and casting cubes of fluid, non-shrink grout for compressive strength tests.

Application Procedure

25 kg of MASTERFLOW® 928 mixed with 4.6 litres of water produces approximately 13.7 litres (0.0137M³) of grout. (Approximately 72 x 25 kg bags per M³), using more or less water to meet consistency requirements, will increase or decrease the yield accordingly. (See instructions for use).

Surface Preparation

All surfaces must be clean and sound. Remove all surface laitence by acid etching or grinding, also dust and debris. All surfaces should be thoroughly wetted 6 – 24 hours before starting and be in a moist condition during placing. Any free surface water must be removed before application.

Mixing

For optimum results a high shear paddle or vane grout mixer should be used. Colloidal impeller mixers are not suitable for use with this product. Air entrainment should be avoided.

For large or continuous placement ensure that adequate mixing capacity and sufficient labour is available. A holding tank fitted with agitation may be used.

Add the correct amount of water for the required consistency to the mixer and then add the complete pack(s) slowly while mixing. Mix for a further 5 minutes until smooth and cohesive.

Strength Development

The strength of the grout is often the determining factor in deciding when loads can be put on structural members or machinery. The strength of the grout is dependent on the amount of mixing water, temperature of the object grouted, curing and age of hardened grout.

Application

Underplate:

Ensure sufficient material is available to complete the work and obtain a continuous fill. Pour from one side only to avoid air entrapment, keeping a head on the grout to promote flow. DO NOT vibrate but rods, straps and chains can be used to aid complete filling. A high gravity feed may also be used.

BASF Construction Chemicals (UK) Ltd,
Albany House,
Swinton Hall Road,
Swinton,
Manchester M27 4DT
Tel: +44 (0) 161 794 7411
Fax +44 (0) 161 727 8547
www.basf-cc.co.uk

Grouting large volumes:

MASTERFLOW® 928 may be used up to 75mm thick sections. Above this the addition of clean, graded 10mm aggregates at up to one to one by weight is recommended. In this instance normal concrete mixers and pumps may be used.

Pumping:

MASTERFLOW® 928 may be placed using piston, ram or diaphragm type grout pumps fitted with ball valves. In all cases, ensure maximum restraint is maintained, otherwise compressive strength will be reduced.

Placing

Diagram (A) illustrates typical placements of MASTERFLOW® 928 in the fluid state utilising straight pouring or pumping techniques to place a bedding mortar under bearing plates. Note that unrestrained areas around baseplates should always be kept to a minimum (<150mm).

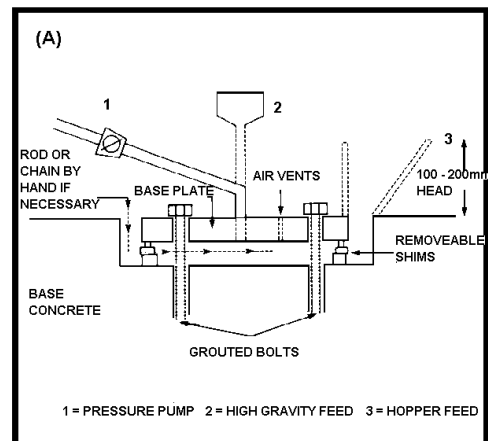

Curing

Good curing is essential on all exposed surfaces particularly in dry, sunny conditions. Failure to do so will reduce bond, strength and durability. Immediately after finishing apply 1 coat of MASTERKURE® 192 or 181 to all exposed surfaces. Alternative methods are water ponding, mist spraying and the like, but in all cases these must be maintained for at least 7 days. Keep the grout above 5°C at all times during application and cure.



The Chemical Company

Note

The fatigue and impact resistance of MASTERFLOW® 928 is exceeded only by metallic reinforced non-catalysed MASTERFLOW® 885. The specially processed metallic aggregate in this product contributes to impact resistance, a desirable property of grout to be subjected to severe dynamic operating forces and repetitive loading such as found in steel and aluminium rolling mills, crane rails, heavy presses, etc.

Packaging

MASTERFLOW® 928 is packed in 25 kg moisture-resistant bags.

Storage

Store in cool dry conditions away from direct sunlight and at ambient temperatures.

Shelf Life

One year when stored in unopened containers according to the manufacturer's instructions.

Watchpoints

The temperature of both the grout and elements coming into contact with the grout should be in the range of 10°C - 25°C. Do not use water in an amount or at a temperature that will produce a flow of less than 20 seconds (CRD-C 79-77) or cause mixed grout to bleed or segregate.

If outside that range, special information on high and low temperature grouting techniques are available from your local BASF Construction Chemicals (UK) Ltd Representative or Technical Services Department. When the grout will be in contact with steel which is or will be stressed to over 550 Mpa, do not use MASTERFLOW® 928. Consult BASF Construction Chemicals (UK) Ltd Technical Services department for steel which will be stressed to over 550 Mpa or for post-tensioned cables and strands.

MASTERFLOW® 928 BASF Construction Chemicals UK Ltd Version 6, July 2006

Health and Safety

*For full information on Health and Safety matters regarding this product the relevant Health and Safety Data Sheet should be consulted.

The following general comments apply to all products.

As with all chemical products, care should be taken during use and storage to avoid contact with eyes, mouth, skin and foodstuffs, (which may also be tainted with vapour until the product is fully cured and dried). Treat splashes to eyes and skin immediately. If accidentally ingested, seek medical attention. Keep away from children and animals. Reseal containers after use.

Solvent Based Products

Use in well ventilated areas; avoid inhaling. Suitable respiratory equipment may be needed, eg when spraying. Can cause skin, eye irritation. Wear protective eye shields and gloves during use. Do not smoke or allow sparks or naked lights when stored or in use.

Powder Products

Should be handled to minimise dust formation; use light mask if excessive dust unavoidable. Cement powders when wet or moistened can cause burns to skin and eyes which should be protected during use.

Resin Products

Can cause irritation, dermatitis or allergic reaction. Use protective equipment particularly for skin and eyes. Use only in well ventilated areas.

Spillage

Chemical products can cause damage; clean spillage immediately.

Disclaimer:

This information and all further technical advice is based on our present knowledge and experience. However, it implies no liability or other legal responsibility on our part, including with regard to existing third party intellectual property rights, especially patent rights. In particular, no warranty, whether express or implied, or guarantee of product properties in the legal sense is intended or implied. We reserve the right to make any changes according to technological progress or further developments. The customer is not released from the obligation to conduct careful inspection and testing of incoming goods. Performance of the product described herein should be verified by testing, which should be carried out only by qualified experts in the sole responsibility of a customer. Reference to trade names used by other companies is neither a recommendation, nor does it imply that similar products could not be used.

BASF Construction Chemicals (UK) Ltd,
Albany House,
Swinton Hall Road,
Swinton,
Manchester M27 4DT
Tel: +44 (0) 161 794 7411
Fax +44 (0) 161 727 8547
www.basf-cc.co.uk